

# LAYOUT OF FUNCTIONAL MODULES AND ROUTING FOR PRELIMINARY DESIGN OF AUTOMATIC TELLER MACHINES

Katsumi Inoue, Tomoya Masuyama, Hayato Osaki, Tokachi Ito

## Abstract:

*In this study we address the preliminary design for the module layout and bill conveyance routes of automatic teller machines (ATMs). We determine a two-dimensional layout for the modules as below that are approximately rectangular if the ATM is viewed from the side. ATMs require the compact placement of modules within the chassis and conveyance routes that smoothly circulate bills. However, the intersection and overlapping of routes by which the bills are conveyed in opposite directions are not allowed. Applying the bottom-left method and route-design-oriented packing method to the layout of the modules and the direction-oriented maze routing expediting branching and interflow of routes to the bill conveyance route, the application orders are optimized simultaneously using genetic algorithms (GAs). Results show that suitable designs for the ATM including the case when modules are selected as well as placed are achievable using the above simultaneous optimization. The design intention is expressible by changing the weights associated with chassis dimensions, route lengths and the number of route bends, which compose the objective function. The proposed method is useful for efficiently advancing the preliminary design of ATMs. Finally, if island models pursuing individual targets are used along with a GA, the design becomes even more efficient.*

**Keywords:** module layout, routing, simultaneous optimization, genetic algorithms, design intention, Island Model

## 1. Introduction

A high demand exists for optimal design through parts-location decision making. This is particularly true for the layout of parts with particular shapes and functions and sequential routing in machinery for chemical plants and ductwork, manufacturing machine location, and conveyer routing. Numerous promising solutions exist for such design problems despite the fact that the problems themselves are numerically limited. For this reason, it is impossible to evaluate each solution. Subsequently, it is necessary to obtain an optimal solution. Regarding simultaneous decision-making processes for the location and routing of parts, Sessomboon and coworkers [1]–[3] examined the problem of machine layout and conveyance routes for automated guided vehicles involved in manufacturing processes. That study concluded that the entire process, namely, the workplace layout designed by the bottom-left (BL) method and the route obtained using graphical method and genetic algorithms (GAs), should be optimized by simulated annealing (SA). Shirai and Matsumoto [4] dealt with workplace block and aisle location issues using the Packing Method for lo-

cation and the Maze Routing Method for determining the aisles' orientation; they carried out optimization by SA as did Sessomboon and coworkers.

The authors [5] studied the above-mentioned optimization issue targeting the preliminary design of automatic teller machines (ATMs). ATMs require the compact placement of modules while avoiding their overlap and a route for bills to circulate smoothly. Moreover, neither the intersection of routes nor the overlapping of routes that convey the bills in opposite directions is allowed, because the direction of bill conveyance in ATMs is fixed. Therefore, the authors [6] decided to use a Maze Routing Method that has high flexibility regarding the shape of the route and can be used to determine the shortest primary path. We improved this method so that the branching and merging can be efficiently performed for ATM functions. We called our method direction-oriented maze routing (DOMR). Meanwhile, in the case of setting multiple routes using the maze-routing method, the route order is generally determined on the basis of the route priorities, which are obtained from information on nesting methods and the amount of traffic, because the solution depends on the search order. In contrast, the authors optimize the route-setting order using GAs and thereby suggest an optimal design method for module layout using the BL method while determining the optimal route using DOMR. The proposed method is generally effective, but some improvements remain regarding the compact placement of modules when there are no restrictions on module shapes.

The arrangement of modules using the BL method is restricted by the module shapes. In this paper, therefore, we first suggest a layout method that combines the secondary allocation issue and the packing method; subsequently, we clarify its effectiveness by applying the method to the preliminary design of ATMs. Next, we evaluate the validity of the design method issues pertaining to its flexibility when modules are to be selected as well as placed. In addition, we demonstrate that designing the arrangement according to specific intentions is possible by changing the weights of the objective function. Lastly, we consider a method of efficient processing by introducing decentralized processing in the GAs using an island model.

## 2. Module layout and route-design issues in preliminary atm design

### 2.1. Modules and Routes to Realize ATM Functions

The overlapping of modules in terms of depth is not apparent if an ATM is viewed from the side. For this reason, ATM design can be conceptualized as a two-dimensional layout problem. Figure 1 shows the placement of the modules in

a grid space  $(x, y)$ . We refer to the individual grid areas as cells. All modules are rectangular; the location of module  $i$  is expressed in centroid coordinates as  $P_{gi}(x_i, y_i)$ . To simplify the design task, the route is set as being parallel to the axis. Our method does not deal with shapes with diagonals. In addition, the route has a direction for bill conveyance; only one route exists in each cell. Table 1 shows the names of the modules and their dimensions in cell units. Figure 2 illustrates the bill conveyance routes that connect the modules containing the bill-out and bill-in apertures.

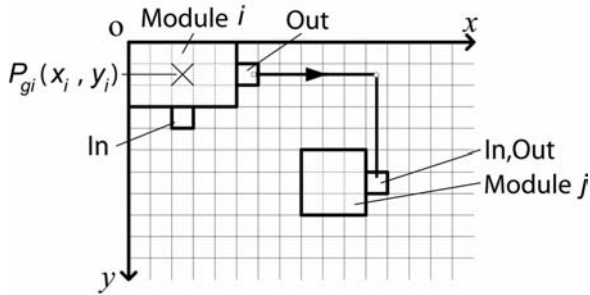

Figure 1. Module and route modeling.

Table 1. Modules of ATMs.

Code	Module	Size
A	Bill entrance unit	5*3
B	Bill verifying unit	3*5
CA	Temporary stacker A	3*3
CB	Temporary stacker B	3*3
D	Loading cassette	5*9
K1	Cashbox 1	3*9
K2	Cashbox 2	3*9
K3	Cashbox 3	3*9
R1	Reject box 1	5*3
R2	Reject box 2	5*3

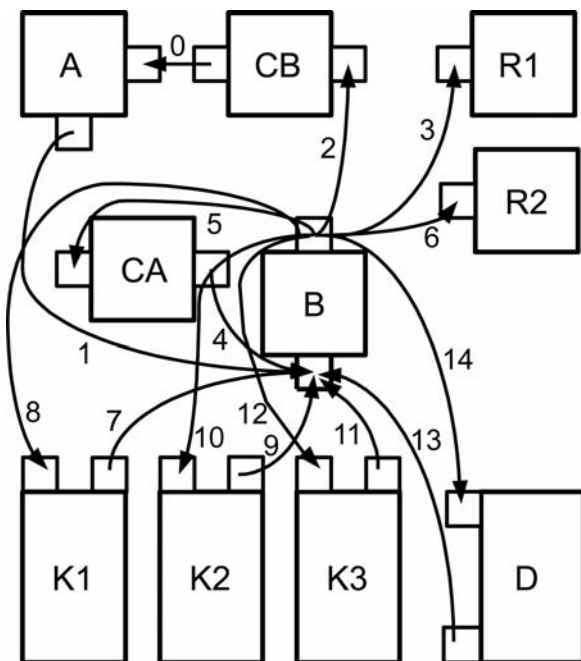

Figure 2. Module layout and routing.

Every ATM requires the flows of bills to realize the four functions shown in Figure 3. For example, in the case of a deposit, after validating the bill in the bill-verifying unit B, which has come from the bill entrance unit A, different processes might ensue: i) a bill might be returned to the bill entrance unit; ii) a defective bill might be stored in reject box R1 or R2; or iii) a bill might be stored in cashbox K1-K3 for subsequent reuse. The bills are conveyed along different routes according to the situation. A total of 15 routes are necessary to implement all the necessary functions; these routes are illustrated in Figure 2. The module codes and route numbers indicated in Figure 3 are those shown in Table 1 and Figure 2.

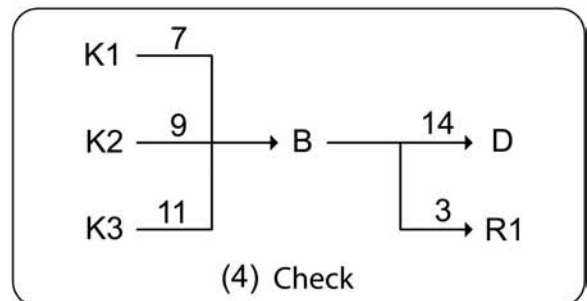
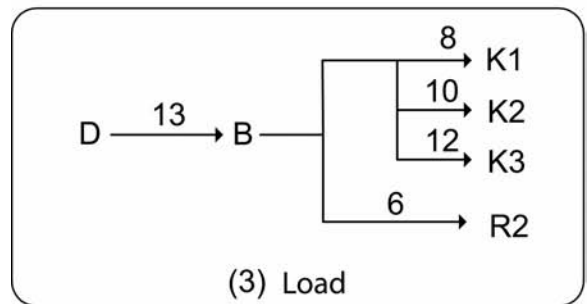
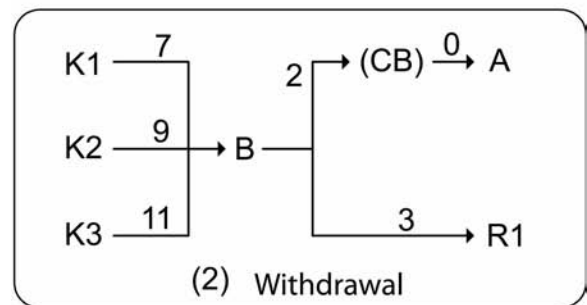
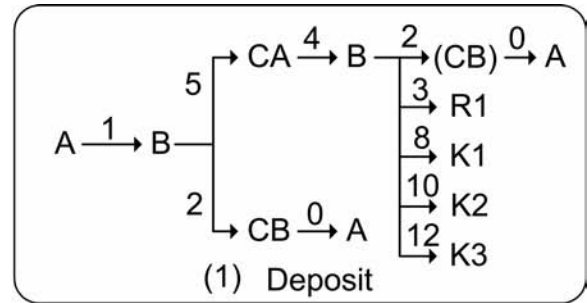

Figure 3. Modules and routes necessary for ATM functions ((1) deposit, (2) withdrawal, (3) load, (4) check).

**2.2 Formulation of the Design Problem**

This design method aims to place  $m$  rectangular modules that differ in dimensions and to set  $n$  routes. The following information is required.

1. Dimensions, i.e., vertical and horizontal lengths, of modules,
2. Locations of bill-in and bill-out apertures for each module,
3. Modules at the starting point and ending point of each route.

On the basis of this information, the design problem is formulated as follows.

$$\min. f_0 = w_1 L + w_2 B + w_3 C + w_4 S \quad (1)$$

In this equation,  $L$ ,  $B$ ,  $C$  and  $S$  are penalties, as below:

$L$ : Total route length by cell unit;

$B$ : Number of route bends;

$C$ : Number of crossings with other routes;

$S$ : Size of the smallest rectangle that contains the modules.

As mentioned above, those penalties are expressed by the number of cells. Weights  $w_j$  correspond to the respective performances; the values assigned to them reflect the designer's intention. For instance, if the weight of  $S$  increases, the design places more emphasis on compactness. If the weights of  $L$  and  $B$  are increased, the route length and number of bends are expected to decrease; such a design accelerates ATM processing. The bill conveyance routes do not intersect. Therefore,  $C$  must be zero. However, it is difficult to express this condition as positive in the objective function. Therefore, the objective function is expressed as a linear combination including  $C$ ; and intersections are avoided by assigning a large weight to  $C$ . In this design, the number of modules  $m$  is 10 and the number of routes  $n$  is 15.

### 3. Method of module layout and routing

#### 3.1. Layout Design of Modules

Various methods such as (a) the quadratic assignment program (QAP) [7], (b) computerized relationship layout planning (CORELAP) [8], and (c) flexible bay structure (FBS) [9] have been proposed for the layout design of modules. Method (a) deals with the problem of distributing  $N$  modules among  $N$  candidate sites. The modules, however, are defined as points; they are not considered as shapes. In method (b), the modules are considered as shapes, but because other modules are sequentially adjacent to one module, the concavity and convexity of the outer shapes become critical. In method (c), candidate sites at which modules are placed first determined in rows. Then the modules are loaded every row. Accordingly, this method results in a comparatively orderly module layout.

If an ATM is viewed from the side, it be regarded as a two-dimensional layout. Methods (b) and (c) thereby become applicable. Size and shape differences among the modules are considerable, and the number of modules to be arranged is comparatively small. Consequently, the following two layout methods were chosen for this study.

##### (1) BL Method [10]

In the original method, modules are inserted from the upper right of the layout area; they are first moved to the bottom and then to the left until the modules can no longer be moved. Figure 4 shows an example of layout

design using this method. Here, module 3 is inserted at first, next, module 2, 4 and 1 are inserted in order. In this study, the upper and left boundaries are set. Module A, the bill entrance unit, is fixed in the upper left of the area; thus, the BL method is applied under the upper-left condition. One empty cell is reserved around individual modules to secure a route-setting area. The BL method determines the layout according to the order of module placement. Therefore, the order of placing the modules in the layout area is the variable in this design problem.

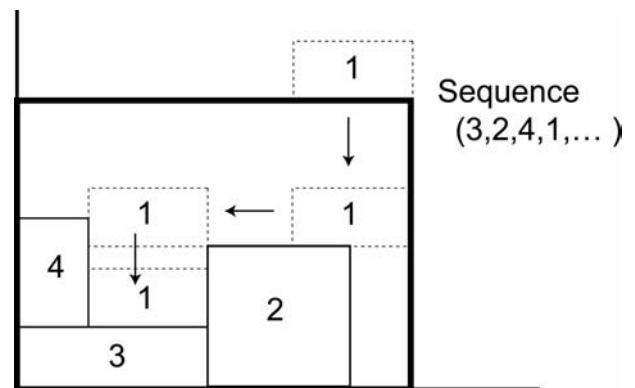

Figure 4. Algorithm of the BL method.

##### (2) RDOP Method

The modules' shapes sometimes restrict layout design using the BL method. Therefore, we suggest a layout design method that combines the secondary allocation issue and the packing method. We call this route-design-oriented packing (RDOP) method. The flow of this method is depicted in Figure 5. It is similar to the BL method in that the upper and left boundaries of the layout area are fixed. The modules are placed in the following order.

##### Step 1:

To secure the route-setting area, one empty cell is placed to the right and below the modules containing the bill-in and bill-out apertures, as shown by the shaded areas in the Figure 5. Equal-sized rectangular areas, which can accommodate all the modules including the extra spaces mentioned above, are allocated in the grid. The number of rectangular areas is identical in both the vertical and horizontal directions and is the minimum number required to accommodate all the modules. The number of modules is 10 in this design problem. Therefore, the number of rectangular areas is  $4 \times 4 = 16$ , as shown in Figure 5(a).

##### Step 2:

Figure 5(b) shows that modules are moved to the upper left of the rectangular areas based on the module layout information.

##### Step 3:

The border lines of the design area are moved simultaneously up and to the left, until they abut other modules. This process is portrayed in Figure 5(c).

Using this method, it is possible to produce a compact layout without being restricted by the modules' shapes. The design variables for this method are the module arrangement information that is initially given for the rectangular areas.

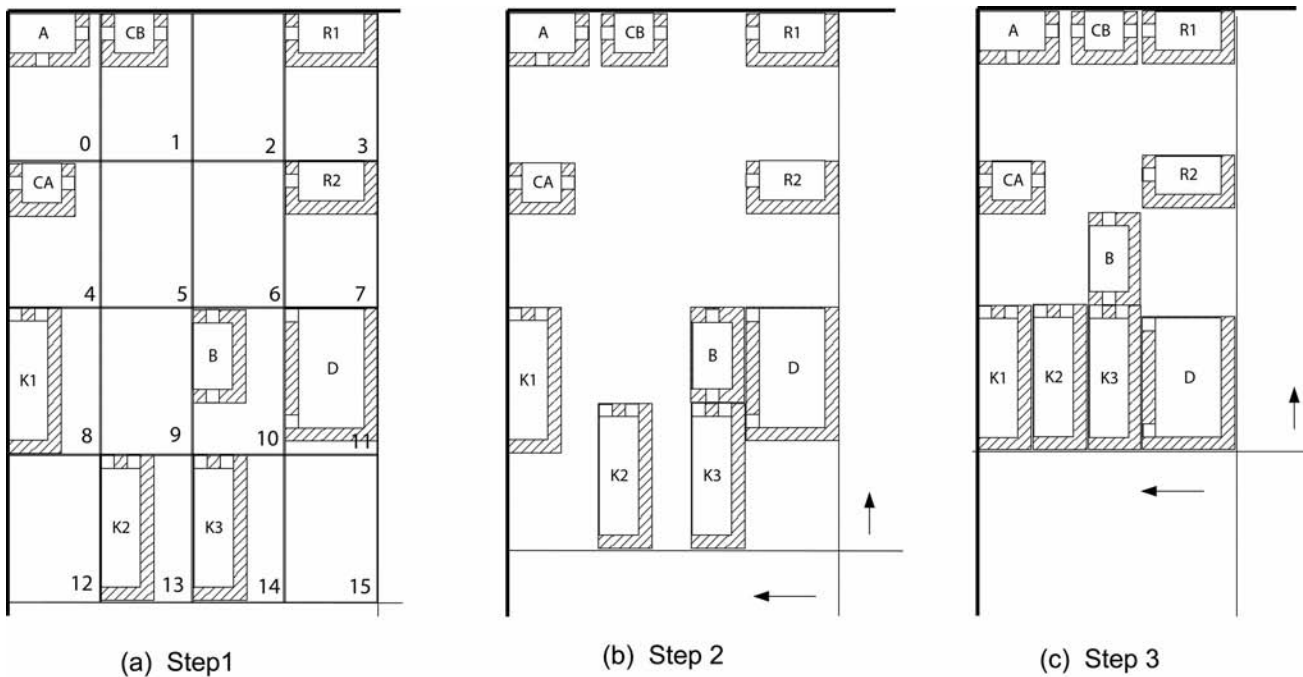

Figure 5. Algorithm of the route-design-oriented packing method.

### 3.2. Route Design by Direction-Oriented Maze Routing Method

The maze-routing method has been used in such cases as wiring design in VLSI [11]; this method provides the shortest route from the starting point to the end point in the design area while avoiding obstacles. For instance, to avoid obstacles in Lee's algorithm [12], weights are applied to the labels. Existing routes are considered as obstacles. Therefore, this weighting is effective for the avoidance of route crossings. However, route crossings are actually unavoidable in this problem because the routing for bill conveyance in ATMs is complicated.

For ATM design, the bill-conveyance direction is set for every route. Although the intersection and overlapping of conveyance routes with route in the opposite direction are not permitted, branching and merging are allowed in route design, under the condition that the routes proceed in the same direction. Branching and merging should be promoted because merging has the advantage of shortening the total length of routes. Consequently, a new maze-routing method is suggested using labeling that encourages merging while prohibiting intersection and overlapping with routes in the opposite direction. This method is called direction-oriented maze routing (DOMR) [6].

Figure 6 shows the process of labeling and route searching using the DOMR method. In Figure 6(a), the white rectangular blocks represent modules. Solid lines and arrowheads respectively indicate existing routes and their directions; the broken line is the route that is chosen from starting point  $S$  to terminal point  $T$ .

The obstacles described above are denoted as  $X$  in Figure 6(b). The cell that is under consideration is  $S'$ , and the newly labeled cells are  $S''$ ; the initial state is  $S'=S$ , and label  $L_s$  is 1. Label numbers are given to  $S''$ , which are located above, below, left and right of  $S'$  by the following procedure. Here, four more cells in the same directions are also considered at each stage [4].

Rule 1:

The stage is terminated without labeling if cell  $S''$  is  $X$ .

Rule 2:

If the label value of  $S''$  already exists and it is smaller than the label value to be given, then the stage is terminated without updating the label.

Rule 3:

If the label value does not exist for  $S''$  or if it does exist but is larger than the label value to be given, then the label value is updated.

Rule 4:

If  $S''$  is not on an existing route,  $S''$  is moved to the cell next to where it was initially located as in  $L_s'' = L_s + 20$ . (Here, the added value to the label, +20, is to be adjusted according to the area size and the route). In the example shown in Figure 6(b),  $S'$  is the cell (3, 4) and the labeling of  $S''$  is performed in the regions (1, 4)-(2, 4) and (4, 4)-(7, 4).

Rule 5:

The following sub rules are applied if  $S''$  is on an existing route that is in the same direction as the cell to be labeled or  $S''$  is on the point of inflection.

- 1) If the new label value to be given to  $S''$  is less than that of the cell next to  $S''$  and on the  $S'$  side, then the stage is terminated without updating  $S''$ .
- 2) In other cases,  $L_s'' = L_s' + 1$  is applied.  $S''$  is moved by one more cell if it is on the forward-direction route. An example of this case when  $S'$  is at (3, 5) and  $S''$  is at (3, 6)-(3, 9) in Figure 6(c).
- 3) The stage is terminated if  $S''$  is on the point of inflection. For example, when  $S'$  is at (3, 4) and  $S''$  is at (3, 5) in Figure 6(b).

Rule 6:

If  $S''$  is on an existing route and is neither in the forward direction nor at a point of inflection, the turn is terminated by labeling  $L_s'' = L_s' + 120$ . (This additional value of +120 is also to be adjusted according to the area size and the route.) This case is represented by the situation when  $S'$  is at (3, 5) and  $S''$  is at (4, 5) in Figure 6(c).

Rules 4-6 enable branching and merging. Using these rules, the minimum label is given to the cell that is on an existing route in the same direction. Therefore, the newly determined route merges with an existing route as soon as possible and proceeds along this existing route for as long as possible.

Following these rules, the operation is repeated with the newly labeled  $S''$  as  $S'$  until all cells have been completely updated; the result is shown in Figure 6(c). After having finished labeling, as in Lee's algorithm, the algorithm searches up/down and left/right from the starting point T. A new starting point  $T'$  is created if a smaller label number exists than the current value. The label with the smaller number of cell movements is adopted if the same label numbers exist. The process continues until  $T'$  reaches S. This process is portrayed in Figure 6(d). The symbol denotes  $T'$ . The route from T to S passing through  $T'$ , if the point  $T'$  reaches S.

#### 4. Simultaneous optimization of design based on ga

##### 4.1. Simultaneous Optimization of Module Layout and Route Design

The design of the module layout and route is affected by the order of module placement, as mentioned above. Therefore, it is necessary to optimize this order. For the optimization method, we use a GA [13].

In the BL method, to express 10 modules and 15 routes, the integers 0-24 are used as strings. Figure 7 shows the string composition. The genetic loci 0-9 represent the module numbers shown in Table 1. As shown in the figure, the order of information extracted from the genetic locus determines the insertion order for the modules. Loci 10-24 are the route numbers shown in Figure 2 or Figure 3 with 10 added to them. Therefore, deducting 10 from these values in the genetic locus gives the information is

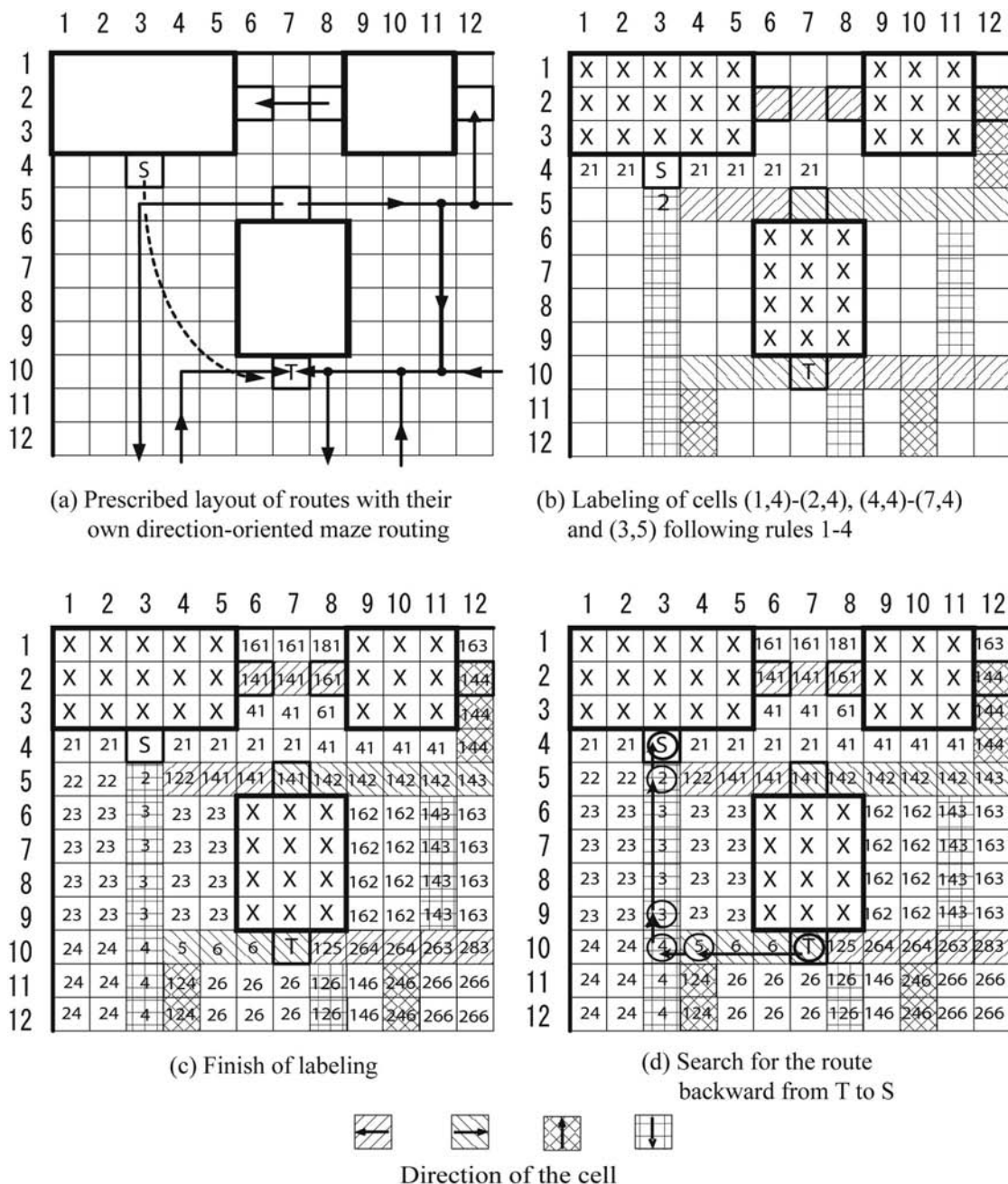
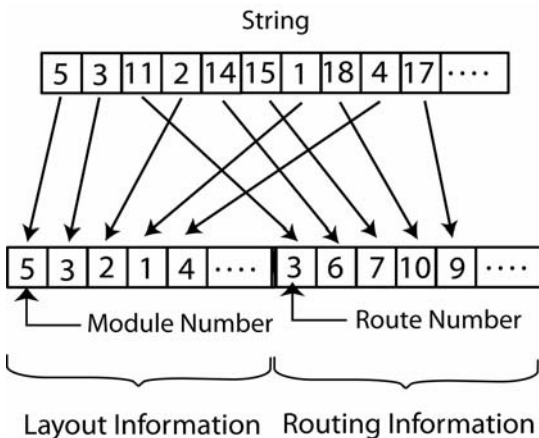

Figure 6. Creation of a route from S to T by proposed direction-oriented maze routing.

useful for the route-setting order. In the RDOP method, the module numbers are determined by using the numbers 10 to 15, which refer to "empty" modules, as well as actual module numbers 0-9. These numbers correspond to the 16 rectangular areas that accommodate the modules. While extracting information from strings 0-15 in the genetic locus, the corresponding modules are placed in accordance with the numbers given to the rectangular areas in advance. The following string represents the module arrangement shown in Figure 5(a).

0-3-10-8-2-11-12-9-5-13-1-4-14-6-7-15

The route-setting procedure is identical to that of the BL method.



Layout Information Routing Information  
 Figure 7. String used for simultaneous optimization and decoding of present design variables.

The flowchart of the design optimization method is shown in Figure 8. The steady-state GA [14] based on a continuous generational model is used in this study. In the case that an individual created by a crossover or mutation is superior to the worst individual in the population, the worst individual is replaced by the created one. A high probability of creating individuals with a fatal gene that includes the same modules and routes exists if a simple crossover is used. Therefore, the ordered crossover is used here.

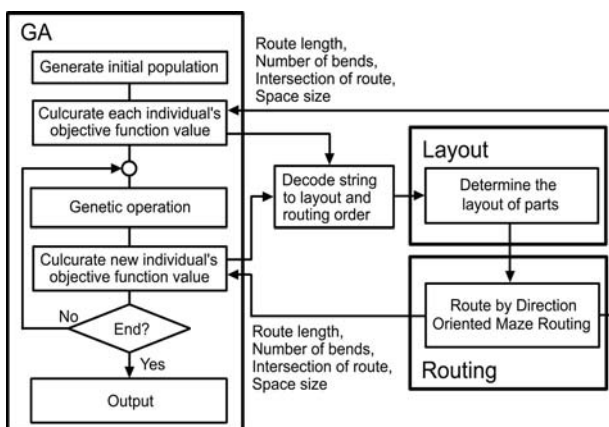

Figure 8. Flowchart of design optimization method.

**4.2. Solution Obtained by Simultaneous Optimization**

Design of ATM is calculated by setting the weights to  $w_1=3$ ,  $w_2=20$ ,  $w_3=100$ , and  $w_4=4$ , and the population size to 100; the mutation rate is 0.3, and the number of genera-

tions is 30,000. Figure 9(a) shows the optimized solution based on the BL method; the module layout and routes are obtained without overlapping between modules to modules, or between modules and routes. In addition, there are no intersections or overlapping routes in opposite directions. The relative locations of modules B, CA, CB, D, K1, K2, K3, and R2 are similar to the module arrangement for an actual machine. The obtained layout of modules is compact, and the route length  $L$  is 78. The objective function calculated using Equation (1) is 2454.

The solution in the case of using the RDOP method is shown in Figure 9(b). As presented in the previous section, a concern exists regarding the possibility of a declining rate of superior-individual creation because of the use of longer strings than those used for the BL method. Therefore, we set the population size to 200, the mutation evolution rate to 0.2, the number of generation to 100,000, which increases the calculation load. In this case, the weights in Equation (1) were set to  $w_1=3$ ,  $w_2=20$ ,  $w_3=100$ , and  $w_4=1$  because the RDOP method provides efficiently minimizes the layout space. All the terms of the objective function are improved compared with those shown in Figure 9(a). The improvement of the area and route length appears to be attributable to the effect of the empty cells placed around the modules when setting the routes. Furthermore, the number of bends is greatly decreased.

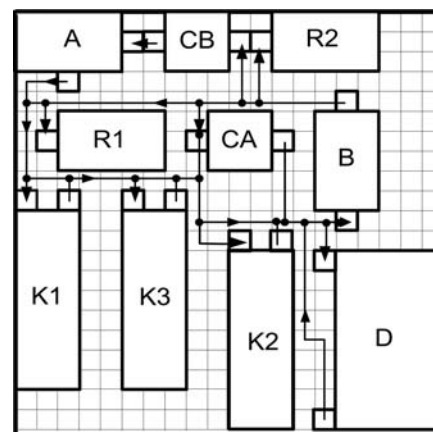

(a) by BL method

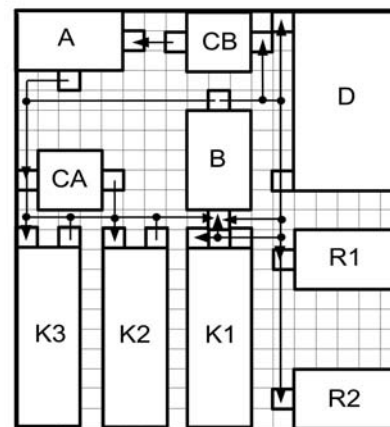

(b) by RDOP method

Figure 9. Module layout and routes optimized by the (a) BL method and (b) RDOP method.

### 5. Layout design including module selection

In actual design, it is often the case that great flexibility exists in selecting the modules to be used. It is easy to select from among distinctively different options. For instance, whether to select high-cost and high-reliability modules or low-cost and low-reliability modules depends solely on the design goal as to whether low cost or high reliability is sought as a design priority. Alternatively, it is often possible to select modules based on product specifications. Here, we apply the design method presented in the previous section to a problem that does not appear to be affected by module selection.

Table 2 shows the modules that can be chosen for the design. The sizes of the modules shown in the table are almost identical to those of the modules used in the layout design in the previous section. On the other hand, the shapes and locations of the bill-in and bill-out apertures differ. The information on the module selection is expressed in two bits in the form of a string that is newly created for the 10 modules that are placed. This coding method differs from that used for the string described earlier. Therefore, we apply a one-point crossover to the module selection string.

Table 2. Selectable modules for ATM design.

Parts	Plan 1	Plan 2	Plan 3	Plan 4
<A> Bill entrance unit				
<B> Bill verifying unit				
<CA><CB> Temporary stacker				
<D> Loading cassette				
<K1> <K2> <K3> Cash box				
<R1> <R2> Reject box				

The optimal layout is calculated using the weights  $w_1=3$ ,  $w_2=20$ ,  $w_3=100$ , and  $w_4=4$ , population size of 500, a mutation evolution rate of 0.3, and the 200,000 generations. Figure 10(a) shows the optimal design in the case of using the BL method. The numbers shown in the figure represent the module numbers. By selecting appropriate modules, a better solution is obtained than that shown in Figure 9(a). The decrease in the number of bends is particularly noteworthy.

Figure 10(b) illustrates the optimal solution in the case of using the RDOP method. Although different modules are selected from those shown in Figure 9(b), no marked

improvement is found in the value of the objective function. The reason for this lack of improvement has not been clarified, but a contributing cause might be the fact that the RDOP method is less affected by the modules' shapes than the BL method. The superiority to the BL method is the same as that of the design that does not include module selection.

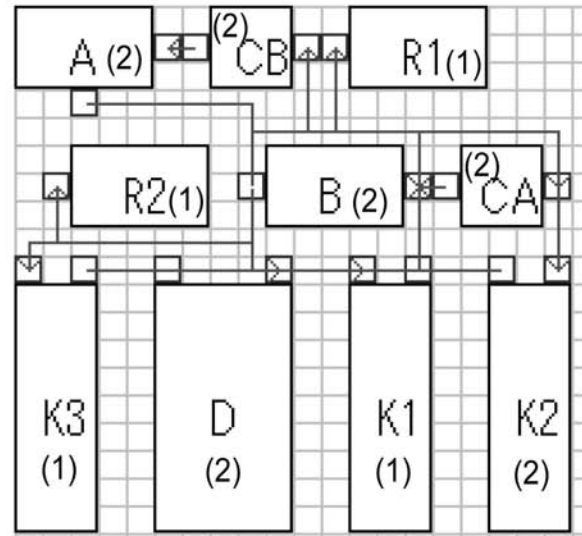

$L=68, B=20, C=0, S=380, f_0=2124$

(a) by BL method

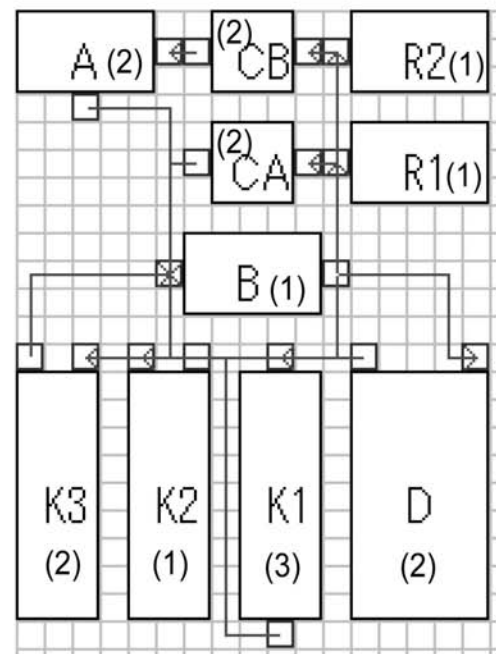

$L=67, B=15, C=0, S=391, f_0=942$

(b) by RDOP method

Figure 10. Module layout and routes optimized by the (a) BL method and (b) RDOP method with module selection.

The distribution of solutions for each method is shown in Figure 11. Error bars in the figure indicate standard deviations. Despite the greater dispersion, the RDOP method is superior to the BL method. Moreover, its superiority for design with module selection is clear.

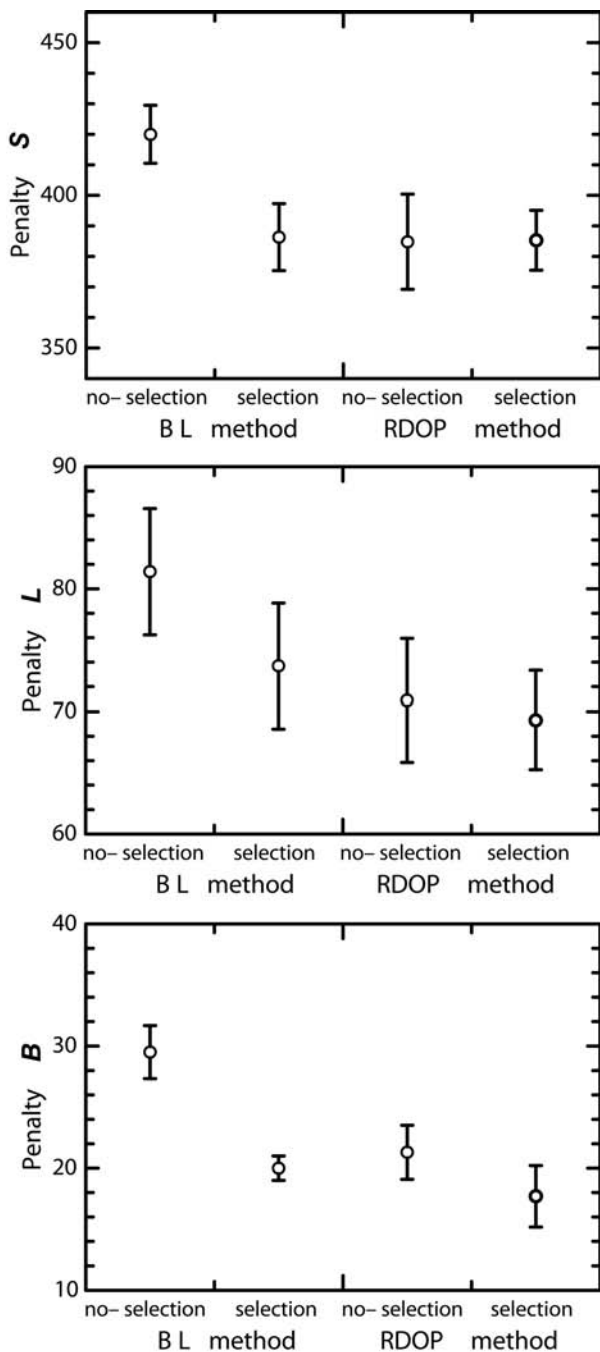

Figure 11. Penalties incurred by each method.

Good results can be achieved by applying the design methods along with the selection of modules with various characteristics. In addition, the method described in this section might be applicable to the research and development of modules with the characteristics required for product design with high performance.

## 6. Realization of the design intention

As described in section 2.2, design intentions can be expressed by tuning the value of each weight  $w_j$  in the objective function, Equation (1). This section examines this matter. We discuss three design intentions; (a) minimization of module layout space, (b) minimization of routing length, and (c) minimization of number of route bends. The values of weights for these design intentions are shown in Table 3. Design intention (a) result in a solution that realizes the miniaturization of the machine, and (b)

and (c) result in solutions that maximize the machine's speed.

Table 3. Weights of objective function for each design intention.

Design	Intention	$w_1$	$w_2$	$w_3$	$w_4$
(a)	minimize space	1	10	100	4
(b)	minimize route length	10	10	100	1
(c)	minimize number of bends	1	40	150	1

In each case, applying the BL method and the RDOP method, designs including the selection of parts were generated three times. The optimum solutions that were obtained in each case are shown in Figure 12. All components of the objective function, for which the weight factors were increased, are reduced, thereby realizing the design intentions. In design (c), which used the BL method, the design contained a route intersection. The cause is inferred to be that the search for a solution did not converge, but another possible cause is the coexistence of the difficult objectives of minimizing route bends and avoiding route intersections. To illustrate a similar result, recall the previous section, in which a good solution was obtained when the RDOP method was used.

## 7. Introduction to distributed process of GA and its effect

An island GA is sometimes used as a method of increasing GA efficiency. Here, relatively small populations evolve independently by repeating the genetic operations in each island, then they are mixed through mutual immigration. This idea was adapted to the present design task using two different island models. One is a conventional island model and the other is, as shown in Figure 13, an island model based on the idea of realizing the design intention by changing the weights, which was considered in the previous section. These island models are called island model 1 and island model 2. Island model 2 is introduced based on the idea that an independent design with high-performance can be implemented a comprehensive high-performance design. Using this method, it is expected that the search for a solution has greater efficiency than that of a conventional island model (island model 1). In addition, because increasing the performance of individuals can provide more optional solutions, it is expected to diversify the populations. For the proposed island models, the weight distribution ( $w_1=1$ ,  $w_2=10$ ,  $w_3=100$ , and  $w_4=1$ ) is used for a multipurpose design intention, as shown in Table 3.

Island models 1 and 2 have 500 individuals each. The top 100 individuals are received as immigrants from another island; the other individuals are rejected. After 30,000 generations, the initial immigration is carried out; subsequent immigrations are performed every 10,000 generations. The simulation was ended after the 100,000th generation.

The objective functions for both island methods starting from the same initial group of individuals are shown in



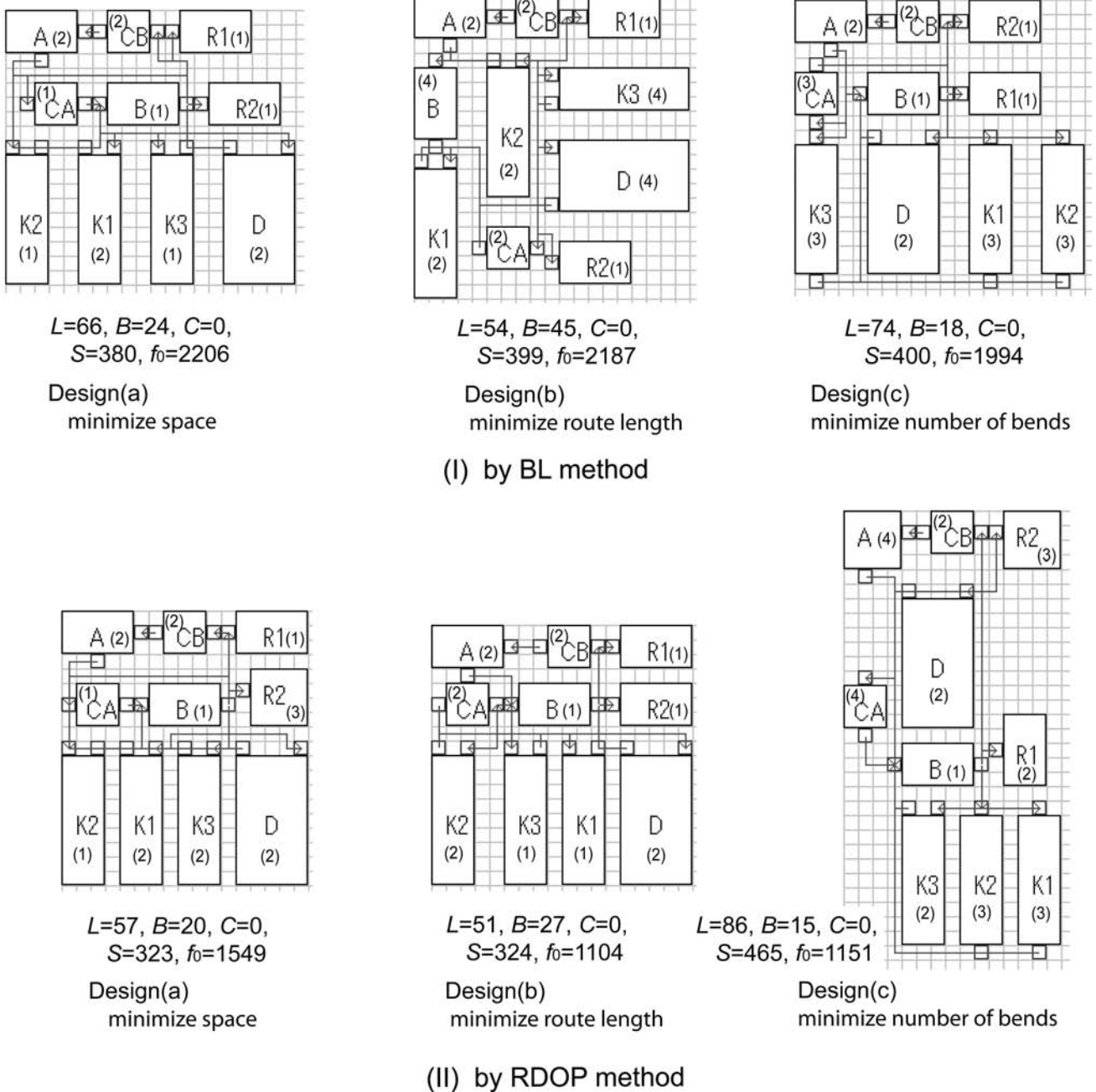

Figure 12. Module layout and routes reflecting different design intentions.

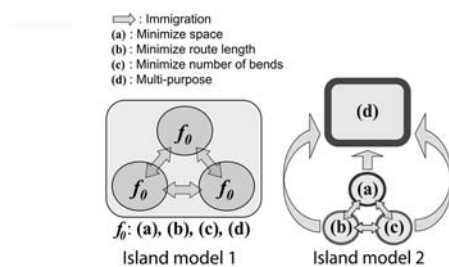

Figure 13. Island model concept.

Figure 14. Both models converge to excellent solutions. The designs obtained for island model 2 and a non island model are shown in Figure 15. For each design intention, objective functions obtained by applying the island models are summarized in Figure 16. Values given are averages over three trials for each condition, and are expressed as a ratios to the results achieved without using island models.

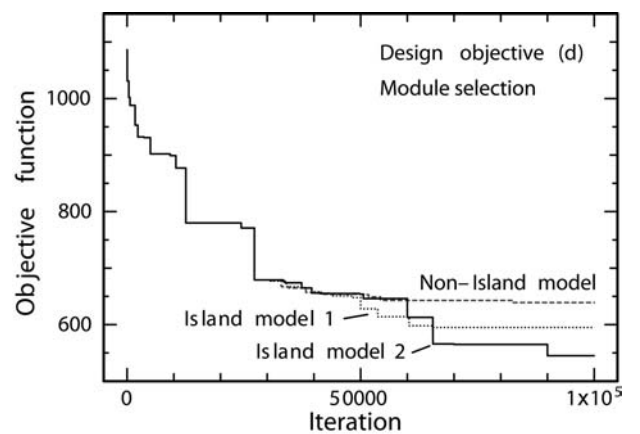

Figure 14. Comparison of reduction of the objective function using island models.

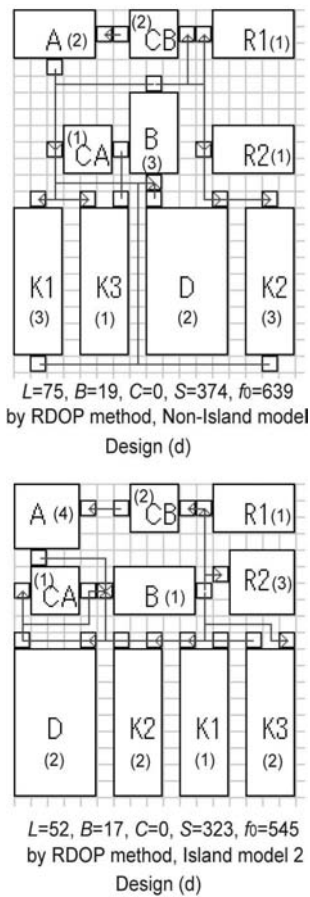

Figure 15. Comparison of module layout and routes obtained using island model 2 and a non island model.

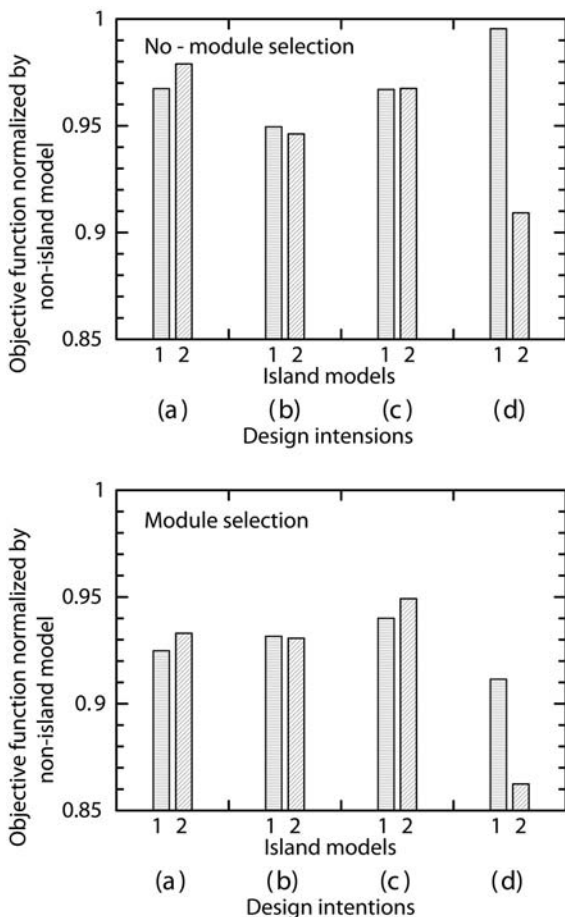

Figure 16. Objective functions obtained using two island models.

For the selection of modules, it is inferred that the application of island models is more effective because the range of the solution search is greater. For both the selection and non selection of modules, superior solutions were obtained using island model 1 for design intentions (a) and (c). For this reason, minimizing the area and minimizing the number of route bends are antithetical items. It seems to be ineffective to receive immigrants that have achieved performance gains for the realization of these intentions. On the other hand, for design intentions (b) and (d), good solutions were obtained using island model 2; results were particularly outstanding for (d). It is considered that receiving immigrants that achieved individual performance gains was effective for obtaining multipurpose optimum solutions.

### 8. CONCLUSIONS

ATMs require the compact placement of modules while avoiding their overlap and routes for bills to circulate smoothly. Moreover, the intersection of routes is not allowed; the overlapping of routes that convey the bills in opposite directions is also not allowed because the bill-conveyance direction in the ATM is fixed.

On the basis of these conditions, we present and discuss methods of optimizing the layout of modules with various functions and the routes connecting them to obtain appropriate solutions simultaneously during the preliminary design. The main results of this study are the following.

- 1) A method was suggested for solving this design problem by combining the BL method or the RDOP method for module layout design with DOMR for route design and by simultaneously optimizing the process using a GA.
- 2) The RDOP method demonstrates better performance than the BL method.
- 3) The suggested method was applied to design problems with different intentions including the case when modules are selected. Good design solutions were obtained using the method.
- 4) While independently advancing the design to enhance the performance of individuals, their achievement was used as a basis for multipurpose design. On the basis of the concepts presented above, unique island models were proposed and their effectiveness was confirmed.

### ACKNOWLEDGMENT

The authors sincerely appreciate Dr. Kunio Fukatsu from Toshiba Social Automation Systems Co., Ltd., for his useful advice regarding this work.

### AUTHORS

**Katsumi Inoue** – Department of Mechanical Systems and Design, Tohoku University, Japan.

E-mail: inoue@elm.mech.tohoku.ac.jp

**Tomoya Masuyama\*** – Department of Mechanical Engineering, Tsuruoka National College of Technology, Japan.

E-mail: masu@tsuruoka-nct.ac.jp

**Hayato Osaki** – YAMAHA Motor Co., Ltd. Japan.

E-mail: oosakihayato@yamaha-motor.co.jp

**Tokachi Ito** – TOYOTA Motor Co., Ltd. Japan.

E-mail: ito@elm.mech.tohoku.ac.jp

\* Corresponding author

## References

- [1] Sessomboon W., Nakano H., Irohara T. and Yoshimoto, K., "A Technique to Solve Dynamic Layout Problem with Fixed and Rectangular Departments"; *Transactions of the Japan Society of Mechanical Engineers, Series C*, vol. 63-615, 1997, pp. 4050-4056. (in Japanese)
- [2] Sessomboon W., Murofushi T., Irohara T. and Yoshimoto K., "A Layout Technique for Unequal Area and Shape Departments Considering Main Aisle"; *Transactions of the Japan Society of Mechanical Engineers, Series C*, vol. 63-615, 1997, pp. 4057-4064. (in Japanese)
- [3] Sessomboon W., Sugiyama M., Irohara T. and Yoshimoto K., "A Design Technique of AGF Flow Path by Considering Machine Layout"; *Transactions of the Japan Society of Mechanical Engineers, Series C*, vol. 64-617, 1998, pp. 370-376. (in Japanese)
- [4] Shirai Y. and Matsumoto N., "Simultaneous Optimization of Floor and Aisle Planning for Facility Layout Problems"; *Transactions of the Japan Society of Mechanical Engineers, Series C*, vol. 65-632, 1999, pp. 1593-1600. (in Japanese)
- [5] Masuyama T., Kobayashi T., Fukatsu K., Yamanaoka M. and Inoue K., "Layout Design of Functional Modules and Connecting Routes (Tuning of Weight in GA-based Design of Automated Teller Machine)"; *Journal of Japan Society for Design Engineering*, vol. 36, no. 4, 2001, pp. 157-163. (in Japanese)
- [6] Inoue K., Osaki H., Masuyama T. and Fukatsu K., "Layout Design of Functional Modules and Routing for Their Connection Considering the Route Divergence and Confluence (Layout Design of Modules and Routing for Automatic Teller Machine)"; *Transactions of the Japan Society of Mechanical Engineers, Series C*, vol. 68-655, 2002, pp. 331-338. (in Japanese)
- [7] Koopmans T.C. and Beckmann M.J., "Assignment Programs and Location of Economic Activities"; *Econometrica*, 1957, vol. 25, 1957, pp. 53.
- [8] Lee R.C. and Moore J.M., "Computerized Relationship Layout Planning"; *Journal of Industrial Engineering*, vol. 18, no. 3, 1967, pp. 194-200.
- [9] Tate D.M. and Smith A.E., "Unequal-area Facility Layout by Genetic Search"; *IIE Transactions*, vol. 27, no. 4, 1995, pp. 465-472.
- [10] Stefan J., "On Genetic Algorithm for the Packing of Polygons"; *European Journal of Operational Research*, vol. 88, no. 1, 1996, pp. 165-181.
- [11] Kimura M., Shiraishi Y., Himeno F., Hanaki, S. and Kusaoke M., "A Grid-Free Maze Router"; *The Institute of Electronics, Information and Communication Engineers Transactions, Series A*, vol. J74-A-8, 1991, pp. 1294-1301. (in Japanese)
- [12] Lee C.Y., "An Algorithm for Path Connections and Its Application"; *IRE Transactions Electronic Computers*, vol. EC-10, 1961, pp. 346-365.
- [13] Goldberg D.E., "Genetic Algorithms in Search, Optimization and Machine Learning", 1989, Addison Wesley.
- [14] Inoue K., Fueki H., Ohmachi T. and Kato M., "An application of Genetic Algorithms to Design of Stiffened Plates". In: *Proc. International Conference on Engineering Design*, International Society for the Science of Engineering Design, 1995, pp. 1369-1377.